

A-A (1 : 1)

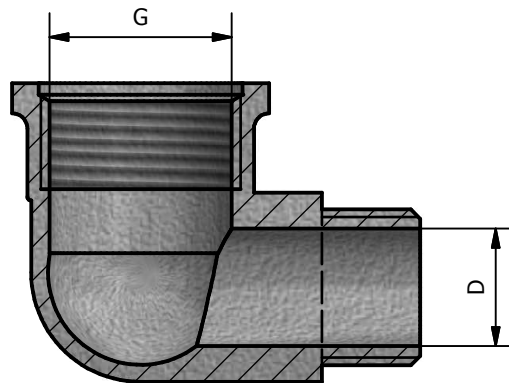

CODE	SIZE	G	G1	D	L	L1	L2	L3	L4
210RN 3412	3/4x1/2	3/4	1/2	15,5	37	25	53	39,5	13
210RN 0112	1"x1/2	1"	1/2	15,5	42,5	37,45	63	53,7	13
210RN 0134	1"x3/4	1"	3/4	20	42,5	37,45	63	53,7	13,75

CONFORMITY

- 1) DM 174 del 6 Aprile 2004
- 2) UNI EN ISO 228
- 3) UNI EN 1254-4
- 4) UNI EN 9227
- 5) UNI EN 2819

WORKING PRESSURE MAX	16 BAR
WORKING TEMPERATURE MAX	120°C

00	Prima emissione	Delaini M.	23/05/2016
Rev.	Nota Revisione	Approvatore	Data Approvazione
Toll Gen:	JS13	Stato sup.:	Nichelato
Filetto:	ISO 228	Note tecniche:	
Peso lavorato:	Peso grezzo:	N° stampo:	
Materiale: CW 617N EN12165		Disegnatore: Delaini P.	Data: 23/05/2016
TDM Brass s.r.l via Artigiani , 7-9 25030 Maclodio BS Italy tel +39 030 9972217 fax 030 9787089 www.tdmbrass.it email info@tdmbrass.it			

Codice: 210RN Scheda

Descrizione: BRASS REDUCED ELBOW F/M NICKEL PLATED